

# DATA SHEET

## Auto Signal Module MD-004

The MD-004 auto signal module provides semi automatic signalling for your model railway track system. In operation the signal is normally set to green, when a train passes the signal a sensor between the rails sets the signal to red. After a predetermined delay time the signal changes to yellow and then after a second time delay it reverts to green. The MD-004 is designed to work with signals that have Light Emitting Diode (LED) lamps fitted. It also provides the voltage required for operation of the LEDs in the signal.

### Specifications:

- Controls one, three light signal
- Input Voltage – 12 – 14 Volts DC
- Sensor – Light Dependant Resistor
- Maximum Output Current – 12 mA

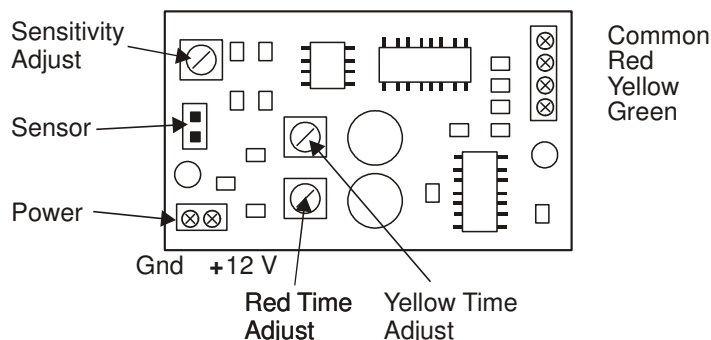

**Figure 1 Auto Signal Module**

### INSTALLATION

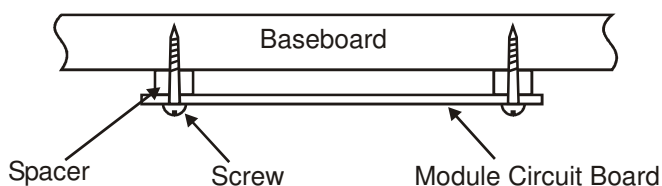

**Figure 2 Module Mounting**

Mount the Module in a position near the signal to be controlled. Use the screw holes provided in the board to mount it but do not fix the screws too tightly or the board may be damaged.

The use of spacers as shown in Figure 2 is recommended.

**Caution – Do not connect more than one signal to each signal module output or use filament (grain of wheat) light bulbs. This will permanently damage the module.**

Connect the wire from the green LED to the terminal designated Green, as shown in Figure 1. Also refer to Figure 3.

Connect the wire from the yellow LED to the terminal designated Yellow, as shown in Figure 1. Also refer to Figure 3.

Connect the wire from the red LED to the terminal designated Red, as shown in Figure 1. Also refer to Figure 3.

Connect the common wire to the terminal designated Common, as shown in Figure 1. Also refer to Figure 3.

**Caution – Take care when making power connections as incorrect connection will permanently damage the module.**

**Caution – Only use a regulated power supply. Unregulated transformers and wall plug units can under certain conditions deliver far more than their rated voltage. Voltages in excess of that specified will permanently damage the module.**

Connect power (12 – 14 V DC) to the power input terminals, refer to Figure 1, taking care to make sure that the positive and negative (ground) wires are inserted in the correct terminals.

## INSTALLING THE SENSOR

Drill a hole through the baseboard positioned in the middle of the track between the sleepers near 25 mm to 50 mm down from the signal position.

Mount the sensor in the hole so that its top is approximately level with the top of the sleepers.

Seal under the sensor with 'Bluetack', or similar, to hold the sensor in place and block any light from entering underneath.

Connect the sensor wires to the terminal block on the module – the wires are not polarised and can be connected to either terminal.

## SIGNAL WIRING

The auto signal module is designed to operate with signals that are fitted with LEDs wired with common cathode. Figure 3 shows the wiring method.

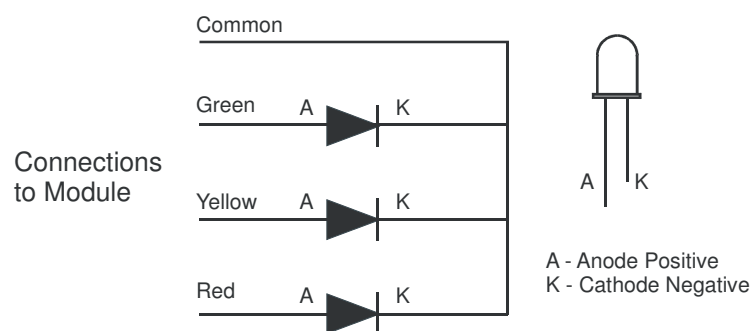

**Figure 3 Signal Wiring**

On some commercial signals, separate ground wires are provided for each LED. In this case connect all ground wires to the common terminal.

## MAKING ADJUSTMENTS

The auto signal module is fitted with three adjustments. These are for adjusting the sensitivity of the sensor and for adjusting the on time for the red and yellow signals.

### Sensitivity

Use a small screw driver to adjust the sensitivity adjuster so the signal shows green. Place a piece of rolling stock on the track and push it over the sensor. If the signal does not change to red adjust the sensitivity adjuster until the signal turns red. Move the rolling stock and wait for the time out period to expire. Check that the signal sets to green. If it does not return to green, repeat the adjustment.

If the signal cannot be made to operate it may be necessary to increase or decrease the ambient light level.

### Signal Red Time

Use a small screwdriver to adjust the time adjuster to obtain the desired delay. The delay can be set from approximately six seconds to sixty seconds.

### Signal Yellow Time

Use a small screwdriver to adjust the time adjuster to obtain the desired delay. The delay can be set from approximately six seconds to sixty seconds.